

Cree® XLamp® XM-L HVW LEDs



PRODUCT DESCRIPTION

The Cree XLamp® XM-L High-Voltage White (HVW) LED provides the lighting-class performance and reliability of Cree XLamp LEDs in the standard XM package. The XM-L HVW LED is an order of magnitude smaller than other high-voltage LED arrays, allowing easy implementation of space-constrained lighting applications with smaller, more efficient high-voltage drivers. Among these applications are lamps such as A19, B10, GU10, MR16, PAR30 and E17.

FEATURES

- Binned at 85 °C
- Typical forward voltage of 46 V @ 44 mA, with Vf binning available
- Cree-standard XM mechanical footprint, with electrically neutral thermal path
- Low thermal resistance: 3.5 °C/W
- Wide viewing angle: 110°
- Maximum drive current: 125 mA
- Maximum junction temperature: 150 °C
- Unlimited floor life at ≤ 30 °C/85% RH
- Reflow solderable
- Available in standard CRI and 80-minimum CRI configurations
- UL-recognized component (E349212)

TABLE OF CONTENTS

Characteristics	2
Flux Characteristics.....	2
Relative Spectral Power Distribution.....	3
Relative Flux vs. Junction Temperature	3
Electrical Characteristics.....	4
Relative Flux vs. Current	4
Typical Spatial Distribution.....	5
Thermal Design.....	5
Reflow Soldering Characteristics ..	6
Notes.....	7
Mechanical Dimensions.....	8
Tape and Reel	9
Packaging.....	10



CHARACTERISTICS

Characteristics	Unit	Minimum	Typical	Maximum
Thermal Resistance, junction to solder point	°C/W		3.5	
Viewing Angle (FWHM)	degrees		110	
Temperature coefficient of voltage	mV/°C		-35	
ESD Classification (HBM per Mil-Std-883D)			Class 2	
DC Forward Current	mA			125
Reverse Current	mA			0.1
Forward voltage (@ 44 mA, 85 °C)	V		46	55
LED Junction Temperature	°C			150

FLUX CHARACTERISTICS (T_j = 85 °C)

The following table provides several base order codes for XLamp XM-L HVW LEDs. It is important to note that the base order codes listed here are a subset of the total available order codes for the product family. For more order codes, as well as a complete description of the order-code nomenclature, please consult the XLamp XM-L LED Binning and Labeling document.

Color	CCT Range		Base Order Codes Min Luminous Flux @ 44 mA			Order Code
	Min.	Max.	Group	Flux (lm) @ 85 °C	Flux (lm) @ 25 °C*	
Cool White	5000 K	8300 K	T3	220	255	XMLHVW-Q0-0000-0000LT351
			T4	240	278	XMLHVW-Q0-0000-0000LT451
			T5	260	301	XMLHVW-Q0-0000-0000LT551
Neutral White	3700 K	5000 K	T2	200	231	XMLHVW-Q0-0000-0000LT2E5
			T3	220	255	XMLHVW-Q0-0000-0000LT3E5
			T4	240	278	XMLHVW-Q0-0000-0000LT4E5
Warm White	2600 K	3700 K	S6	182	211	XMLHVW-Q0-0000-0000LS6E7
			T2	200	231	XMLHVW-Q0-0000-0000LT2E7
			T3	220	255	XMLHVW-Q0-0000-0000LT3E7

Notes:

- Cree maintains a tolerance of ±7% on flux and power measurements, ±0.005 on chromaticity (CC_x, CC_y) measurements and ±2 on CRI measurements. See the Measurements section (page 7).
- Typical CRI for Cool White (5000 K – 8300 K CCT) is 68.
- Typical CRI for Neutral White (3700 K – 5000 K CCT) is 75.
- Typical CRI for Warm White (2600 K – 3700 K CCT) is 82.
- Flux values at 25 °C are calculated and for reference only.

RELATIVE SPECTRAL POWER DISTRIBUTION

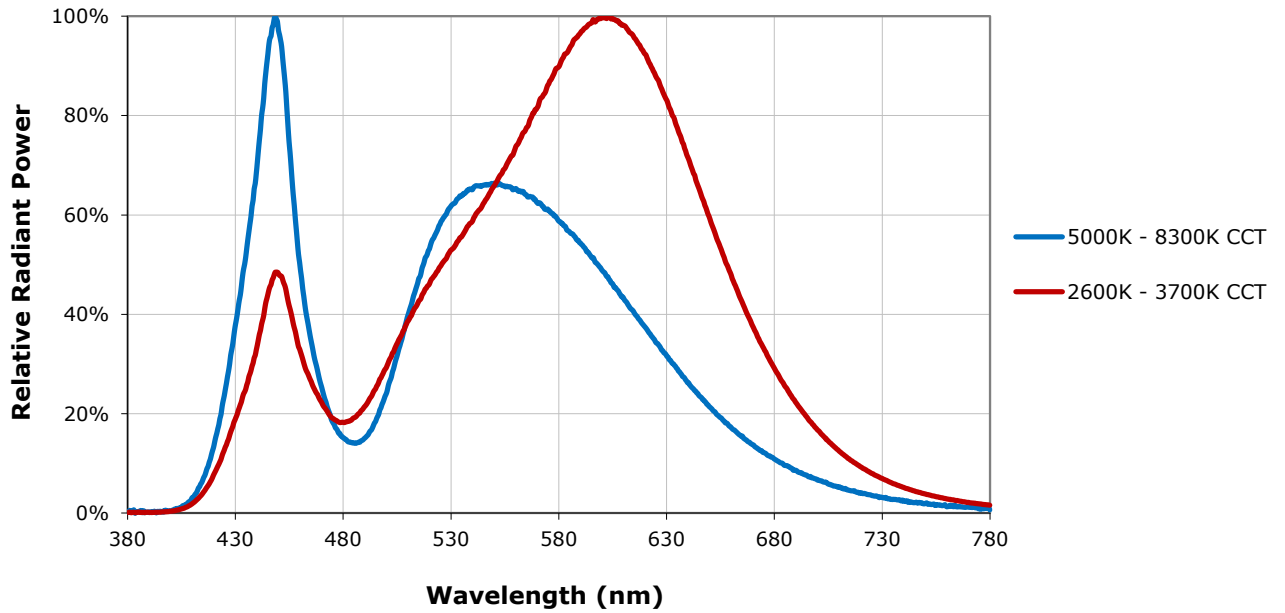

RELATIVE FLUX VS. JUNCTION TEMPERATURE ($I_F = 44$ MA)

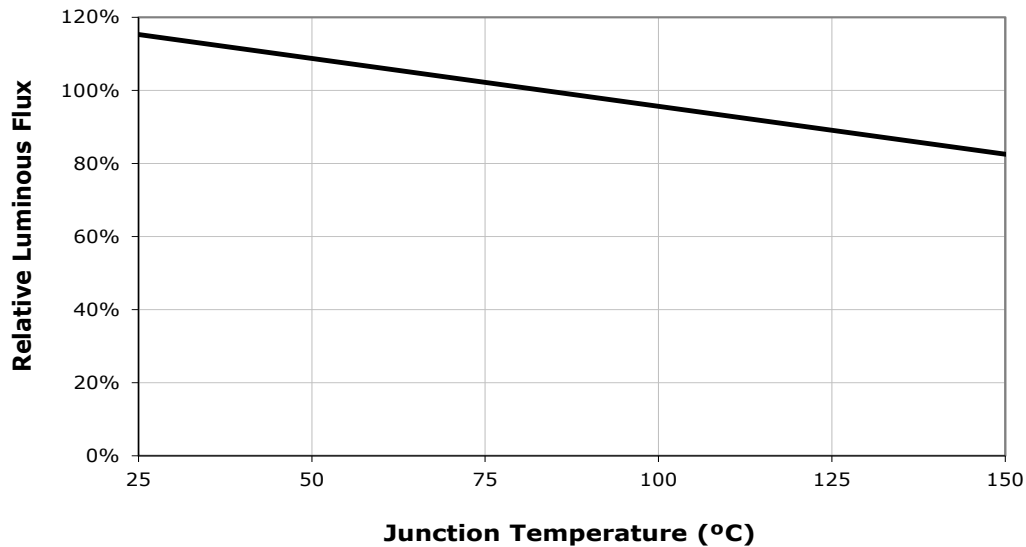

ELECTRICAL CHARACTERISTICS ($T_j = 85\text{ }^\circ\text{C}$)

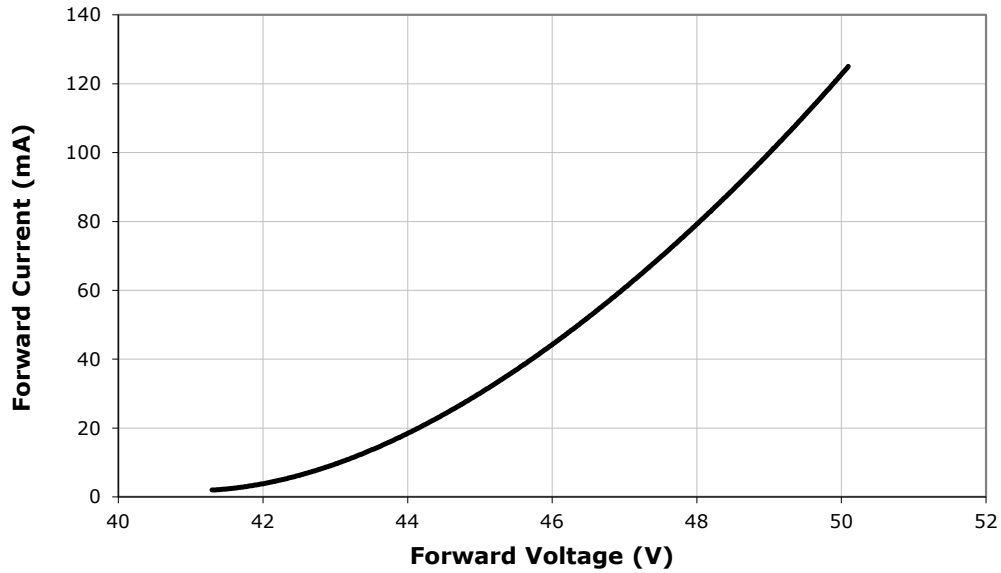

RELATIVE FLUX VS. CURRENT ($T_j = 85\text{ }^\circ\text{C}$)

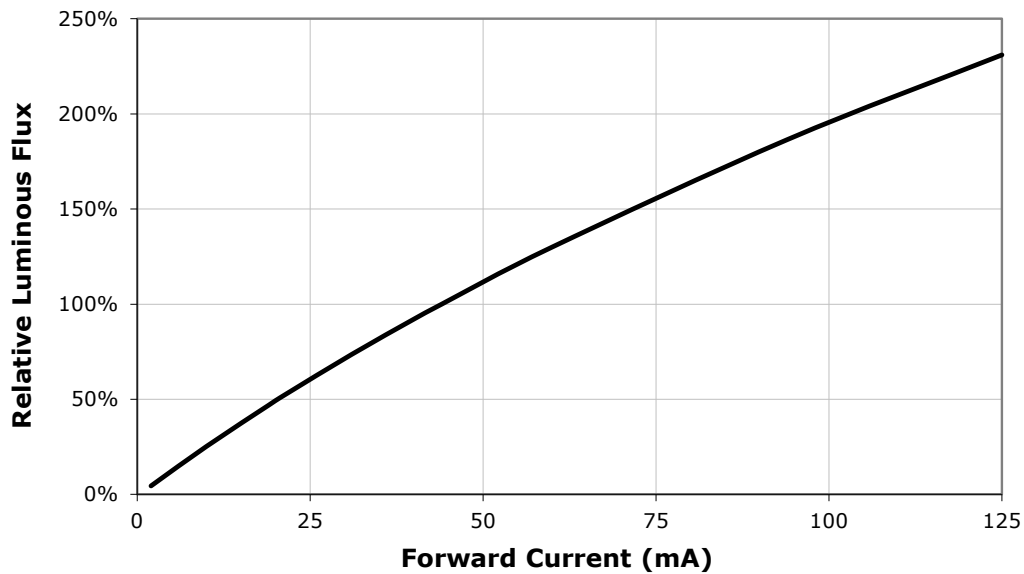

TYPICAL SPATIAL DISTRIBUTION

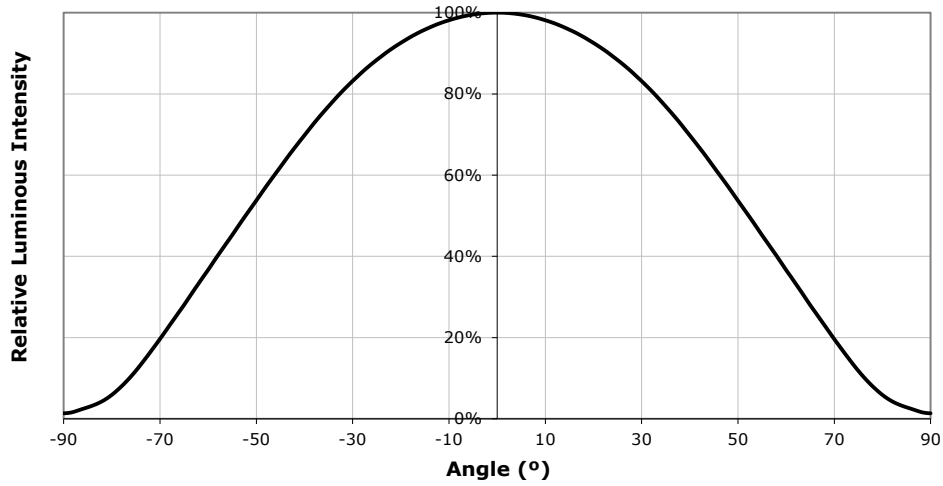

THERMAL DESIGN

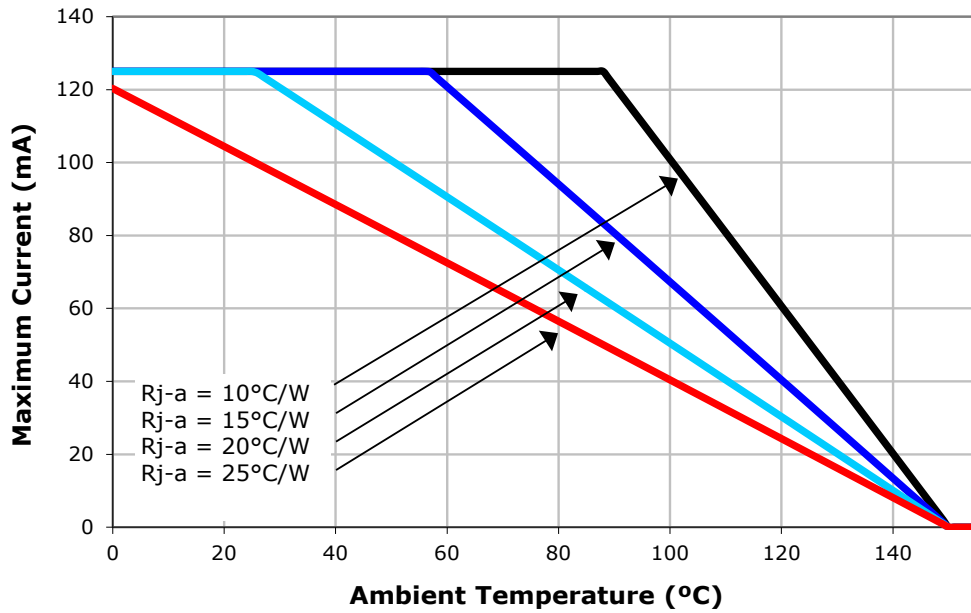

REFLOW SOLDERING CHARACTERISTICS

In testing, Cree has found XLamp XM-L HVW LEDs to be compatible with JEDEC J-STD-020C, using the parameters listed below. As a general guideline, Cree recommends that users follow the recommended soldering profile provided by the manufacturer of the solder paste used.

Note that this general guideline may not apply to all PCB designs and configurations of reflow-soldering equipment.

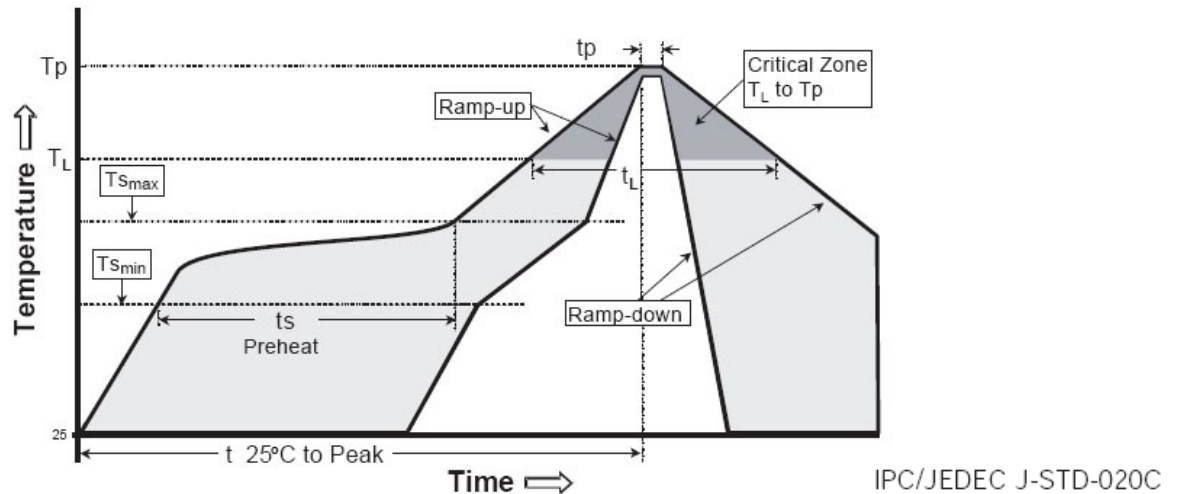

Profile feature	Lead-based solder	Lead-free solder
Average ramp-up rate ($T_{S_{MAX}}$ to T_p)	3 °C/second max	3 °C/second max
Preheat: Temperature min ($T_{S_{MIN}}$)	100 °C	150 °C
Preheat: Temperature max ($T_{S_{MAX}}$)	150 °C	200 °C
Preheat: Time ($t_{S_{MIN}}$ to $t_{S_{MAX}}$)	60-120 seconds	60-180 seconds
Time maintained above: temperature (T_L)	183 °C	217 °C
Time maintained above: time (t_L)	60-150 seconds	60-150 seconds
Peak/classification temperature (T_p)	215 °C	260 °C
Time within 5 °C of actual peak temperature (t_p)	10-30 seconds	20-40 seconds
Ramp-down rate	6 °C/second max	6 °C/second max
Time 25 °C to peak temperature	6 minutes max	8 minutes max

Note: All temperatures refer to topside of the package, measured on the package body surface.

NOTES

Measurements

The luminous flux, radiant power, chromaticity and CRI measurements in this document are binning specifications only and solely represent product measurements as of the date of shipment. These measurements will change over time based on a number of factors that are not within Cree's control and are not intended or provided as operational specifications for the products. Calculated values are provided for informational purposes only and are not intended as specifications.

Lumen Maintenance

Cree now uses standardized IES LM-80-08 and TM-21-11 methods for collecting long-term data and extrapolating LED lumen maintenance. For information on the specific LM-80 data sets available for this LED, refer to the public [LM-80 results document](#).

Please read the [Long-Term Lumen Maintenance application note](#) for more details on Cree's lumen maintenance testing and forecasting. Please read the [Thermal Management application note](#) for details on how thermal design, ambient temperature, and drive current affect the LED junction temperature.

Moisture Sensitivity

Cree recommends keeping XLamp LEDs in the provided, resealable moisture-barrier packaging (MBP) until immediately prior to soldering. Unopened MBPs that contain XLamp LEDs do not need special storage for moisture sensitivity.

Once the MBP is opened, XLamp XM-L HVW LEDs may be stored as MSL 1 per JEDEC J-STD-033, meaning they have unlimited floor life in conditions of ≤ 30 °C/85% relative humidity (RH). Regardless of storage condition, Cree recommends sealing any unsoldered LEDs in the original MBP.

UL Recognized Component

Level 4 enclosure consideration. The LED package or a portion thereof has been investigated as a fire and electrical enclosure per ANSI/UL 8750.

Vision Advisory

WARNING: Do not look at an exposed lamp in operation. Eye injury can result. For more information about LEDs and eye safety, please refer to the [LED Eye Safety application note](#).

MECHANICAL DIMENSIONS

All measurements are $\pm .13$ mm unless otherwise indicated.

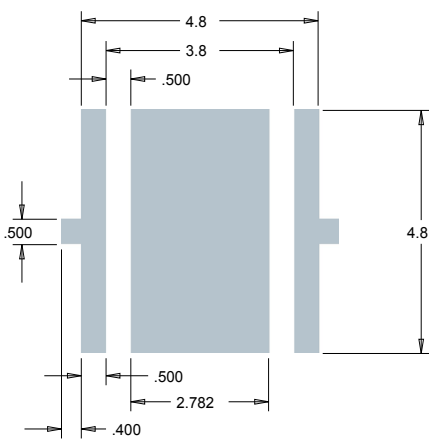
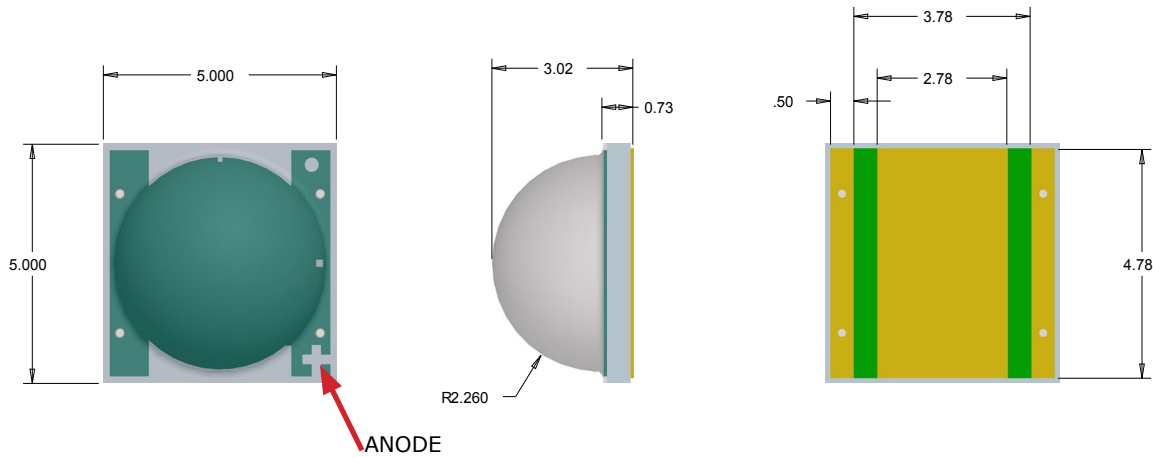

Recommended PCB Solder Pad

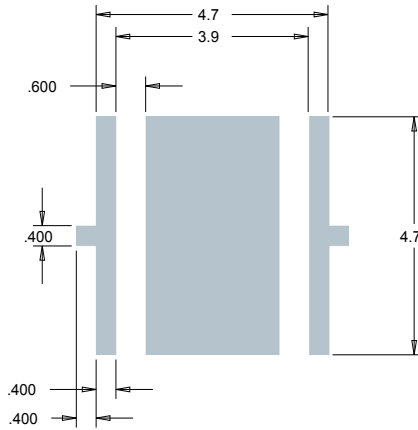

**Recommended Stencil Pattern
(Shaded Area is Open)**

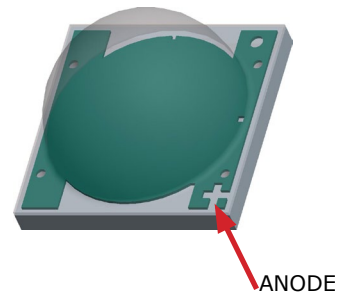

TAPE AND REEL

All Cree carrier tapes conform to EIA-481D, Automated Component Handling Systems Standard.

All dimensions in mm.

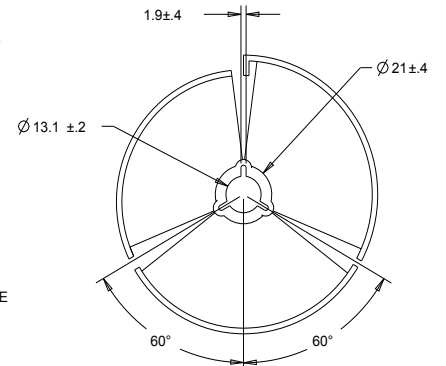
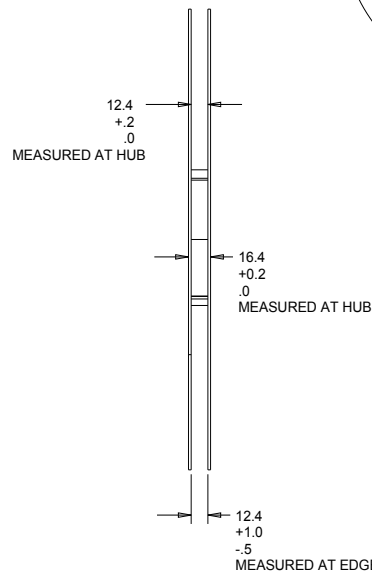
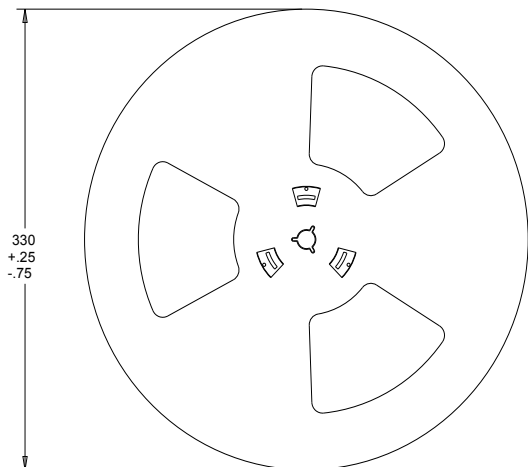
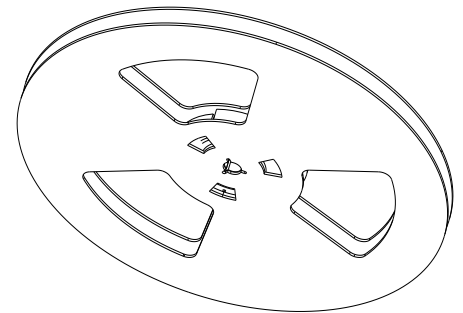
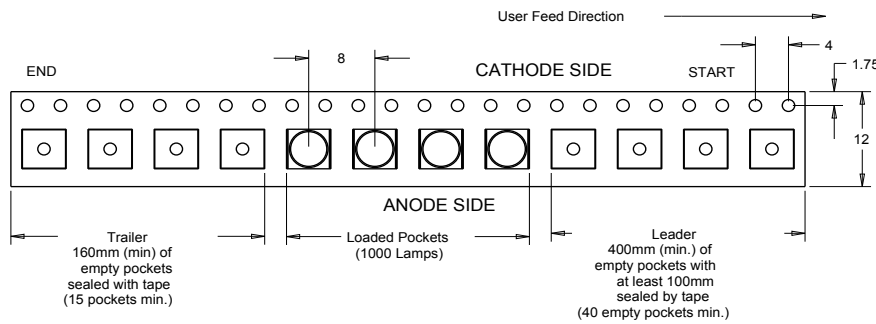
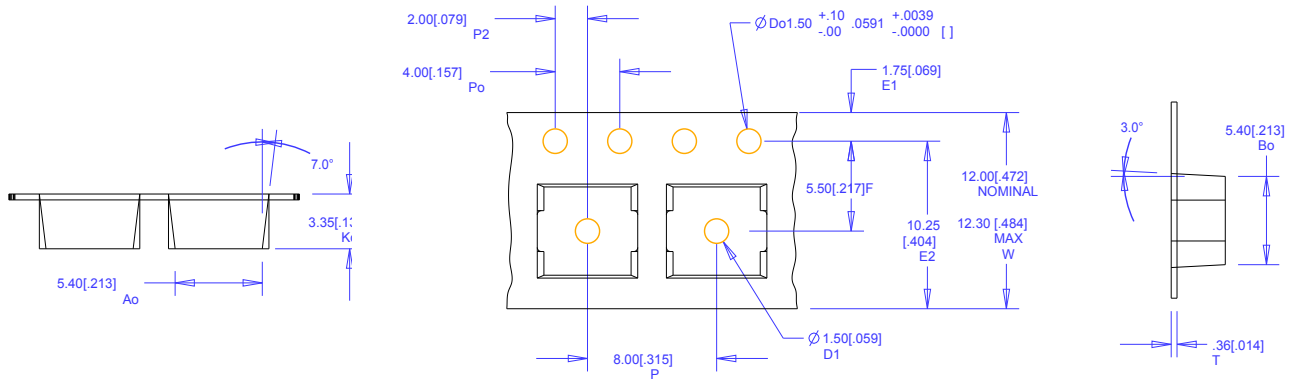

PACKAGING

Unpackaged Reel

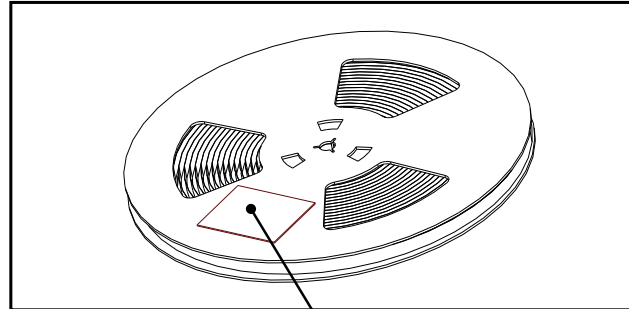

Label with Cree Bin Code, Qty, Reel ID

Packaged Reel

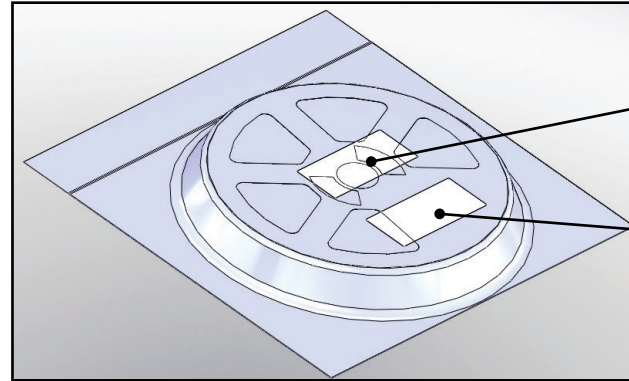

Label with Cree Order Code, Qty, Reel ID, PO #

Label with Cree Bin Code, Qty, Reel ID

Boxed Reel

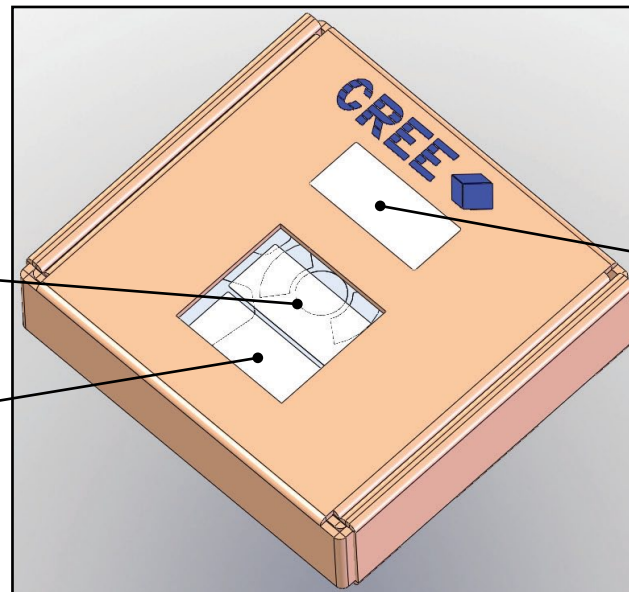

Label with Cree Order Code, Qty, Reel ID, PO #

Label with Cree Bin Code, Qty, Reel ID

Patent Label