

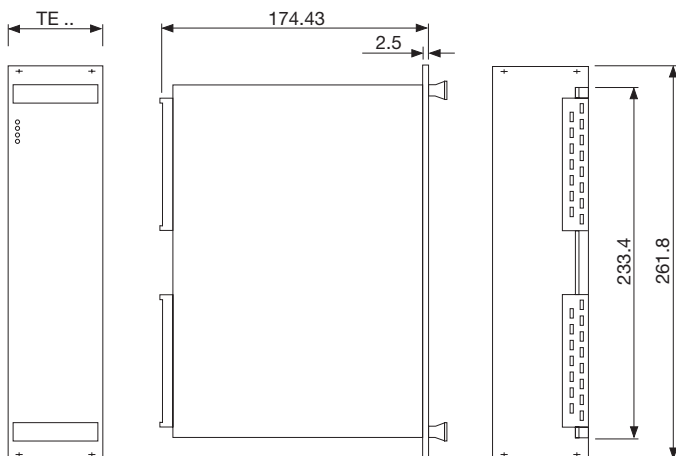

- 19" plug-in module
- Autoranging 120 / 230 VAC
- EMC Standards EN 50081-1 and EN 50082-2
- All outputs permanent short-circuit proof
- Outputs SELV according to EN 60950
- Overtemperature protection
- Optional Power-Fail and ACFAIL-signal



**6HE**

Front panel: 8TE (P 3146) = Handle width  
 Front panel: 12TE (P 3310) = Handle width

ORDER DATA								Order numbers in italics	
Vo1 V	Io1 A	Vo2 V	Io2 A	Vo3 V	Io3 A	Width TE	Height HE	Type No. PF-signal	Type No. ACFAIL-signal
+5.1	0 - 20	+12.1	0 - 5	-12	0 - 2	8	6	<i>P3146-05121PF</i> <i>15.9140.402</i>	<i>P3146-05121AC</i> <i>15.9140.404</i>
+5.1	0 - 20	+15.1	0 - 4	-15	0 - 2	8	6	<i>P3146-05151PF</i> <i>15.9140.502</i>	<i>P3146-05151AC</i> <i>15.9140.504</i>
+5.1	0 - 35	+12.1	0 - 6	-12	0 - 2	12	6	<i>P3310-05121PF</i> <i>15.9140.202</i>	<i>P3310-05121AC</i> <i>15.9140.204</i>
+5.1	0 - 35	+15.1	0 - 5	-15	0 - 1.5	12	6	<i>P3310-05151PF</i> <i>15.9140.302</i>	<i>P3310-05151AC</i> <i>15.9140.304</i>
Total output: Limited to max. 160 W for P 3146									
Additionally:									
Front panel (nature anodized)									
						33.1591.011.011 (P 3146 - 12 V)			
						33.1591.011.111 (P 3146 - 15 V)			
						33.1591.012.011 (P 3310 - 12 V)			
						33.1591.012.111 (P 3310 - 15 V)			

<b>INPUT</b>	<b>SAFETY</b>
Input voltage range AC 187 - 264 V, 50/60 Hz With autoranging to AC 99 - 138 V or DC 264 - 347 V  Efficiency typ. 81% Input current limitation $\leq 25 A_{peak}$ typ. – in cold state $\leq 35 A_{peak}$ typ. – in hot state  Fuse 8 AT	IEC 950, EN 60950 / VDE 0805 Safety Class I, VDE 0100  <b>EMC</b> Interference suppression/ EN 50082-2: 1992 interference immunity EN 61000-4-2 Intensity 4 EN 61000-4-3 Noise level 10 V/m EN 61000-4-4 Intensity 4 EN 61000-4-5 Intensity 4 EN 61000-4-11 VDE 0160 (with shut-down and restart)  Interference emission EN50081-1, EN55011 / EN55022 Class B, interference transmission depends on assembly
<b>OUTPUT</b>	<b>OPERATING DATA</b>
Adjustment range Vo $\pm 5\%$ Operation indicator Green LED for Vi Yellow LED for Vo1, Vo2, Vo3  Ripple Vo1 < 45 mV <sub>pp</sub> Vo2 < 30 mV <sub>pp</sub> Vo3 < 15 mV <sub>pp</sub>  Noise voltage < 80 mV <sub>pp</sub> typ. (total of all noise components) Temperature coefficient 0.025% / K Switch on/switch off No overshooting of Vo (soft-start) performance Rise-delay time < 1 s Run-up time $\leq 15$ ms	Temperature range 0...+70°C, at free convection Derating 3% / K at +50°C Weight 2.0 kg (P 3310), 1.2 kg (P 3146)  <b>Ventilation from bottom to top of the power supply and the housing-specific heatradiation must not be obstructed when installing the power supply. Ensure fire protection by means of the surrounding housing system. In general, kindly refer to the MGV user instructions before use.</b>
<b>REGULATION</b>	<b>MECHANICS</b>
Line regulation < 0.2% for all Vo at Vi 187 - 264 VAC Load regulation < 0.1% for Vo1 at Io 0 - 100% < 1.0% for Vo2 and Vo3 at Io 0 - 100% Response time < 1 ms at Io 20 - 80%	Dimensions 19" plug-in module according to DIN 41494 Part 5 Connection Connector H 15 / DIN 41612 codable
<b>PROTECTION AND CONTROLLING</b>	<b>EXPLANATION</b>
Overvoltage protection 125% $\pm 5\%$ for Vo1 120% $\pm 10\%$ for Vo2 and Vo3 automatically repeating  Current limitation typ. 110% I <sub>nominal</sub> , straight characteristic All outputs permanent short-circuit proof  Overtemperature protection Switches off when inside temperature becomes too high, switches on again with hysteresis.  Mains buffering 20 ms at 100% load Power-Fail The transistor for the PF-signal is blocked, if the output voltage reached a value > 95% of the nominal output voltage. The transistor becomes conductive > 10 ms before the output voltage Vo1 drops.  Signals ACFAIL and SYSRESET TTL-signals with 48 mA drive current, open-collector and low-active-level	<b>PE</b> Protective conductor <b>Do not use supply without PE-connection!</b>  <b>L1/N</b> Mains phase / neutral conductor  <b>L</b> Load connection, (14 A max. for each contact)  <b>F</b> Signal connection (Signal line)  <b>OVL</b> Common ground for Vo1, Vo2, Vo3  <b>Sense lines at 5 V</b> <b>For a safe operating mode of the device, it is mandatory to connect +5VL with +5VF and OVL with OVF. Maximum voltage compensation of 0.25 V of each line.</b>

**PIN CONNECTIONS**

DIN 41612H15	30	26	22	18	14	10	6		DIN 41612H15	30	26	22	18	14	10	6	
	N	near mains	near mains	near mains	1)	1)	SYS-RES			+12VL +15VL	OVL	OVL	OVL	+5VF	+5VL	+5VL	
	32	28	24	20	16	12	8	4		32	28	24	20	16	12	8	4
	PE	L1	near mains	near mains	1)	1)	1)	PF ACFAIL		OVF	+12VL +15VL	OVL	OVL	-12VL -15VL	+5VL	+5VL	+5VL

1) internally connected

