

Speed and Distance

A multi-function watch which helps
You counting your steps

USER MANUAL

1.0 Introduction

Thank you for purchasing this Watch.

This Watch provides Home Time, Dual Time, Daily Alarm, Chronograph, Pedometer and Timer functions.

Besides, this watch can calculate the speed, distance traveled and calories consumption during your walk.

To get the most of your purchase, be sure to read this manual carefully and keep it on hand for later reference when necessary. And it is advised to use this Watch in conformity with the below notes:

- Avoid exposing the Watch to the extreme conditions.
- Avoid rough uses or severe impacts to the Watch.
- Do not open the Watch case unless it is performed by a certified service agency.
- Clean the Watch occasionally with a soft and moistened cloth.
- Store the Watch in a dry place when it is not in use for a long time.

2.1 Major Function Modes

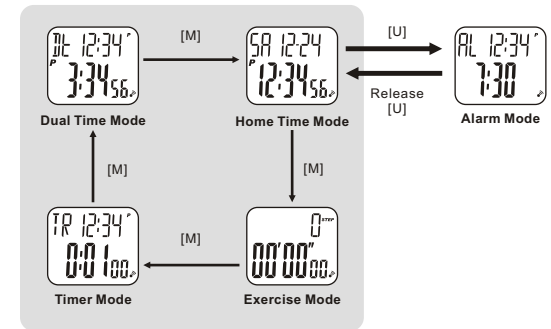

2.0 Buttons Overview

[EL] EL Button

- To turn on the EL back light for about 3 seconds.

[M] Mode Button

- To select among major function modes: Home Time Mode, Exercise Mode, Timer Mode and Dual Time Mode.
- To enter / exit the setting display in Home Time Mode, Timer Mode and Dual Time Mode.
- To select lap recall display in Exercise Mode.
- To select among different setting items in setting display.



[U] Up / Start / Stop Button

- To activate the 'start' / 'stop' function under Exercise and Timer Mode.
- To take Lap records when the chronograph is running.
- To reset counting in Exercise Mode.
- To select Alarm Mode in Home Time Mode.
- To increase the setting value during setting display.

[D] Down / Sub-Function Button

- To select different sub-functional display in Exercise Mode.
- To decrease the setting value during setting.

3.0 Home Time Mode

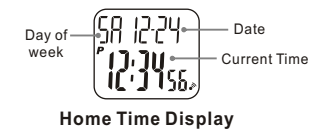

Home Time Mode

- When Home Time Mode is selected, the day of week and date will be exhibited on the 1st row and the current time will be exhibited on the 2nd row.
- Press [U] will go to Alarm Mode.
- Release [U] in Alarm Mode will exit to Home Time Mode.
- Hold down [M] will go into General Setting Display.

3.1 Home Time Mode - General Setting Display

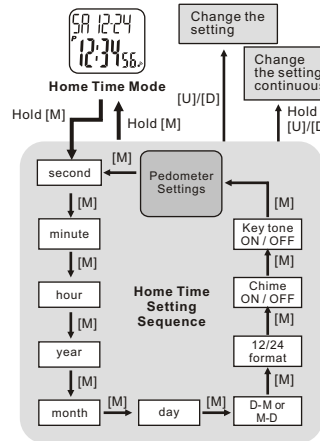

General Setting Display

- In Home Time Mode, hold down [M] to enter the setting display and press [M] to select different setting items (flashing).
- When the second digit start flashing, press [U] or [D] to reset it to zero.
- When one of the settings (minute, hour, year, month or day) is flashing, press [U] or [D] to increase or decrease the setting (Hold down [U] or [D] to change the numbers continuously).
- When 12/24 hour format, D-M/M-D date format, hourly chime ON/OFF or key tone ON/OFF is selected, press [U] or [D] to change the setting.
- If the setting is completed, hold down [M] to exit the setting display.
- If there is no key stroke for more than 1 minute, the watch will return to Home Time Mode automatically.
- For the Pedometer Settings, please refer to Chapter 5.4.

4.1 Alarm Mode - Daily Alarm Setting

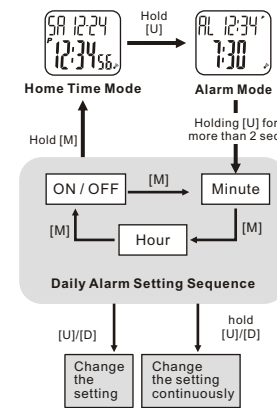

How to Set Daily Alarm

- In Home Time Mode, holding [U] for more than 2 seconds will enter the Daily Alarm setting display:
- Press [M] to select 'minute', 'hour', 'ON/OFF alarm' setting (flashing).
- Press [U] or [D] to change the setting (Hold down [U] or [D] to change the numbers continuously).
- When 'ON/OFF' is flashing, press [U] or [D] to turn ON or OFF the alarm.
- If the setting is completed, hold down [M] to exit the setting display and return to Home Time Mode.
- If there is no key stroke for more than 1 minute, the watch will return to Home Time Mode automatically.

4.0 Alarm Mode

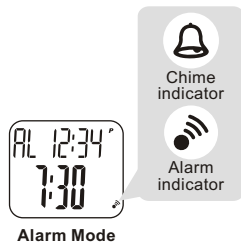

Daily Alarm

- This Watch includes 1 daily alarm for home time.
- When the daily alarm is ON, the Watch will beep for 30 seconds at the alarm time every day.
- When the alarm beeps, press any button to stop the alarm prematurely.

Daily Alarm and Hourly Chime Indicator

- When the Daily Alarm is ON, the Alarm indicator '🔔' will be exhibited on the right-bottom corner.
- When the Hourly Chime is ON, the Chime indicator '🔔' will be exhibited on the right-bottom corner.

5.0 Exercise Mode - Overview



Chronograph Display

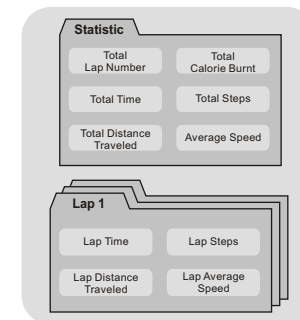

Exercise Mode Overview

- Exercise Mode includes a chronograph which measuring elapse time and lap time.
- Also, it includes pedometer function that help counting user's steps.
- By the information of exercise time, steps and user's profile, this watch can calculate the speed, distance traveled and calories burnt additionally.
- During the exercise, user can select their favorite sub-function display on the upper and lower row for different exercise purposes.
- Besides, this watch can store these exercise information according to laps and total time which helps user to understand and analysis their exercise performance.

5.1 Exercise Mode - Using the Chronograph

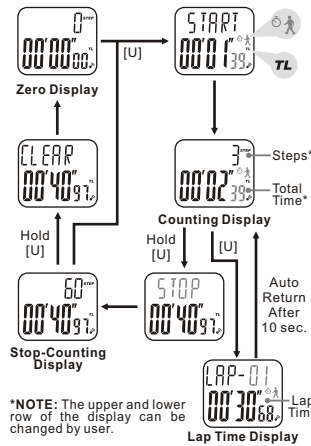

*NOTE: The upper and lower row of the display can be changed by user.

How to Measure Elapsed Time

- Press [U] to start counting ("START" will be exhibited on the 1st row) when the chronograph is stopped. Hold down [U] to stop counting ("STOP" will be exhibited on the 1st row) when the chronograph is running.
- When the Chronograph is running, "⌚" icon will be shown.
- When the Pedometer is running, "🚶" icon will be shown.

How to take a Lap Time

- Press [U] once to take a Lap Time when the chronograph is running. When the Lap Time is shown (Counting time is frozen and no "TL" icon shown), the chronograph is still running.
- After 10 seconds, it will return to normal counting.

How to Reset the Chronograph

- To reset the Chronograph, hold down [U] when the chronograph is stopped.
- NOTE: All the counters of the exercise mode will be reset at the same time

5.3 Exercise Mode - Sub-Functional Display (Lower Row)

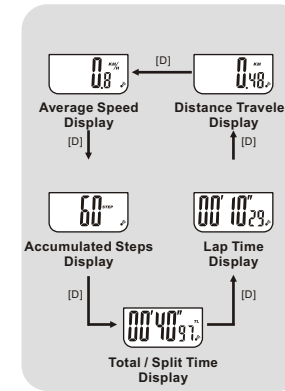

Exercise Information

- The lower row of Exercise Mode provides 5 different Displays for showing the exercise information. They are:
 - Average Speed Display,
 - Accumulated Steps Display,
 - Total / Split Time Display,
 - Lap Time Display and
 - Distance Traveled Display.
- Press [D] to select different exercise information displays from the lower row of the display.
- To reset all counters, hold down [U] in any information display when the chronograph is stopped.

5.2 Exercise Mode - Sub-Functional Display (Upper Row)

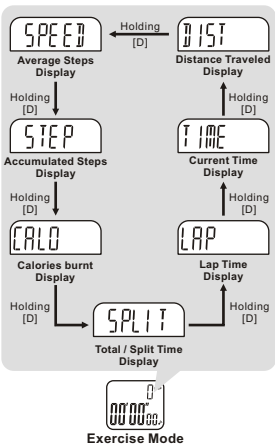

Exercise Information

- The upper row of Exercise Mode provides 7 different Displays for showing the exercise information. They are:
 - Average Speed Display,
 - Accumulated Steps Display,
 - Calories burnt Display,
 - Total / Split Time Display,
 - Lap Time Display,
 - Current Time display and
 - Distance Traveled Display.
- Keep holding [D] to select different exercise information displays from the upper row of the display. When [D] is released, the selected exercise information will be shown.
- To reset all counters, hold down [U] in any information display when the chronograph is stopped.

5.4 Exercise Mode - Pedometer Setting

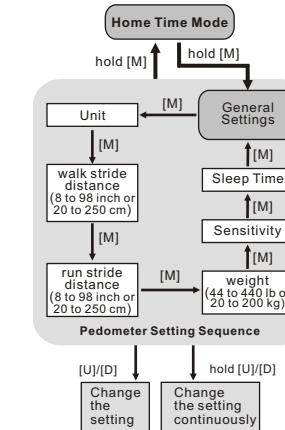

Pedometer Setting

- User can set their personal profile and preference by using this setting.
- **IMPORTANT:** Set the Personal Profile before using the Watch, otherwise some Exercise Mode features CANNOT perform properly.
- **How to Set the Pedometer Setting**
 - In Home Time Mode, hold down [M] to enter the setting display:
 - Press [M] to bypass the General Settings until "Unit" is shown.
 - Press [M] to select the setting items (flashing).
 - Press [U] or [D] to change the setting (Hold down [U] or [D] to change the numbers continuously).
 - **TIPS:** Employ a walking/running for a defined distance (e.g. 100 meters), and count the number of steps (e.g. 200 steps) for accomplishing that distance. The average stride distance can be obtained by: $100 \times 200 = 0.5 \text{ m}$ or 50 cm .
 - **NOTE:** Higher the number of sensitivity is set, the more sensitive of the watch will be.
 - **NOTE:** If no step is detected for a period of time (Sleep Time), the pedometer function will be stopped automatically.
 - If the setting is completed, hold down [M] to exit the setting display.
 - If there is no key stroke for more than 1 minute, the watch will return to Home Time Mode automatically.

5.5 Exercise Mode - Lap Information Recall

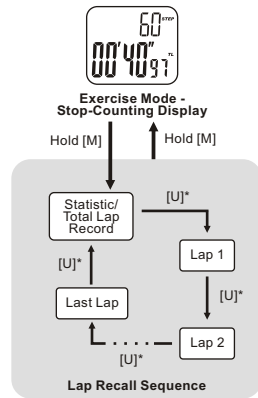

NOTE*:
Press [D] to select in reverse direction.

How to Recall Lap Information

- Hold down [M] in Exercise Mode when the chronograph is stopped will go into the Lap Information Recall display.
- Press [U] or [D] to review different lap records or total lap record.
- Hold down [U] or [D] will select laps at a higher speed, and it will be stopped automatically when Statistic / Total Lap Record is selected.
- Hold down [M] in the recall display will exit and return back to exercise mode display.

NOTE: If there is no lap record, there will be no recall display. Instead, the watch will go to the next mode (Timer Mode) when [M] is held.

5.5.2 Exercise Mode - Individual Lap Record Recall

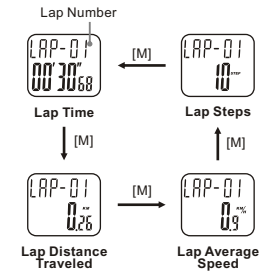

Individual Lap Record

- Beside Total Lap Record, user can also review exercise information for each lap.
- Each lap record contains:
 - Lap Time,
 - Lap Distance Traveled,
 - Average Speed of the Lap and
 - Lap Steps.
- Press [M] to review different information for the lap.
- Press [U] or [D] to review the next /previous Lap records.

5.5.1 Exercise Mode - Statistic / Total Lap Record Recall

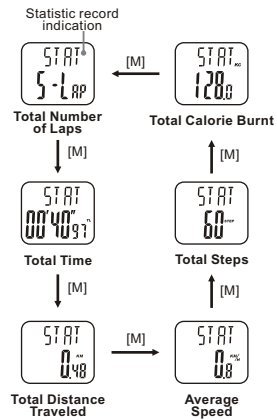

Statistic / Total Lap Record

- This is the first record shown in the recall display.
- This record contains the information for the overall statistic of the whole run which include:
 - Total Number of Laps,
 - Total Time,
 - Total Distance Traveled,
 - Average Speed of the whole run,
 - Total Steps and
 - Total Calorie burnt.
- Press [M] to review different information for the whole run.
- Press [U] or [D] to review next/previous Lap records.

6.0 Timer Mode - Setting Count-down Target

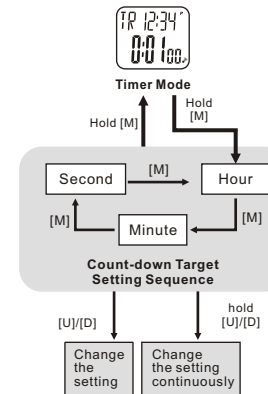

How to Set Count-down Target

- In Timer Mode, hold down [M] to enter the Count-down Target setting display:
 - Press [M] to select 'hour', 'minute', 'second' setting (flashing).
 - Press [U] or [D] to change the setting (Hold down [U] or [D] to change the numbers continuously).
- If the setting is completed, hold down [M] to exit the setting display and return to Timer Mode.
- If there is no key stroke for more than 1 minute, the watch will return to Timer Mode automatically.

6.1 Timer Mode - Using the Count down Timer

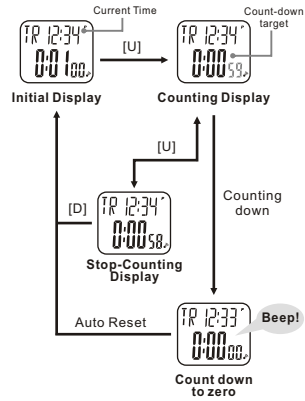

How to use Count down timer

- Press [U] to start counting when the timer is stopped. Press [U] again to stop counting when the timer is running.
- The timer beeps once per minute at the last 10 minutes.
- It beeps once per 10 seconds at the last minute.
- It beeps every second when count down to the last 5 seconds.
- When the timer counts down to zero, it beeps for 30 seconds. After then it will reset to initial count-down target automatically.
- Press any key can turn off the beep sound.
- When the timer is stopped manually, press [D] can also reset the timer to initial count-down target.

8.0 Power Saving Mode

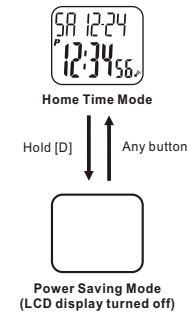

Power Saving Mode

- This Watch includes a Power Saving Function which can turn off the LCD display so that the battery can last longer.
 - While in the Power Saving Mode, the watch function is still worked normally. (i.e. The timekeeping function is still running during Power Saving Mode.)
- ### How to enter / exit the Power Saving Mode
- To enter the Power Saving Mode, hold down [D] in Home Time Mode for about 5 seconds and the LCD display will be turned off.
 - Press any key will exit the Power Saving Mode and the LCD display will be resumed.

7.0 Dual Time Mode - Setting Dual Time

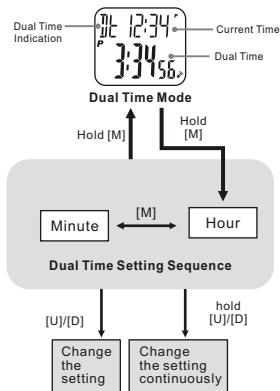

How to Set Dual Time

- In Dual Time Mode, hold down [M] to enter the Dual Time setting display:
 - Press [M] to select 'hour' or 'minute' setting (flashing).
 - Press [U] or [D] to change the setting (Hold down [U] or [D] to change the numbers continuously).
- If the setting is completed, hold down [M] to exit the setting display and return to Dual Time Mode.
- If there is no key stroke for more than 1 minute, the watch will return to Dual Time Mode automatically.

9.0 Specifications

Current Time Mode

- Time System: am, pm, hour, minute, second
- Time Format: 12-hour or 24-hour format
- Calendar: Month, date and day of week display
- Calendar Range from 2000 - 2099
- Hourly Chime

Alarm Mode

- 1 Daily alarm
- Alarm Sound: 30 seconds

Timer Mode

- Resolution: 1 second
- Counting Range: 99 hours 59 minutes 59 seconds

Dual Time Mode

- Hour, Minute Dual Time Setting

Back Light

- Back Light Type: Electro-Luminescent (EL) back light

Exercise Mode

- Chronograph:
 - Resolution: 1/100 second
 - Measuring Range: 9 hours 59 minutes 59.99 seconds
 - 20 Lap memories
- Pedometer:
 - Displayable Steps Range: 0-999999 steps
 - Distance Measuring: 0-360 km / 0-233 mile
 - Speed Measuring: 36 Km/hour / 22.3 MPH
 - Calories Burnt Measuring: 0-99999 calories
 - Sleep Time Setting: 0 - 240 minutes
 - Sensitivity Setting: 5 levels
 - Imperial / Metric unit selection
- Exercise Recall display:
 - Statistic information - Total Lap number, Total Time, Total Distance, Average Speed, Total Steps and Calories burnt
 - Lap information - Lap Time, Lap Distance, Lap Average Speed, Lap Steps